



INTERNATIONAL APPLICATION PUBLISHED UNDER THE PATENT COOPERATION TREATY (PCT)

<p>(51) International Patent Classification⁴ : A61M 1/00, F16T 1/00</p>	<p>A1</p>	<p>(11) International Publication Number: WO 87/ 00439 (43) International Publication Date: 29 January 1987 (29.01.87)</p>
<p>(21) International Application Number: PCT/US86/01502 (22) International Filing Date: 14 July 1986 (14.07.86) (31) Priority Application Number: 755,428 (32) Priority Date: 16 July 1985 (16.07.85) (33) Priority Country: US (71) Applicant: GENERAL POLYMERIC CORPORATION [US/US]; 621 W. Franklin Street, West Reading, PA 19611 (US). (72) Inventor: FERRI, Joseph, E. ; 206 Lester Avenue, Shillington, PA 19607 (US). (74) Agent: BARRON, Alexis; Synnestvedt & Lechner, 3131 PSFS Building, 12 South Twelfth Street, Philadelphia, PA 19107 (US).</p>		<p>(81) Designated States: AT (European patent), BE (European patent), CH (European patent), DE (European patent), FR (European patent), GB (European patent), IT (European patent), JP, LU (European patent), NL (European patent), SE (European patent). Published <i>With international search report.</i></p>

(54) Title: FLUID-FLOW CONTROLLING DEVICE AND APPARATUS EMPLOYING SAME

(57) Abstract

A non-mechanical valve and/or filter device (37) which is suitable for use in an apparatus for aspirating body fluids (14) and which comprises a water insoluble, water-absorbent material which, upon contact with water, becomes substantially impervious to flow through it of gas and liquid in the wetted regions thereof, the preferred form of said device being a porous rigid structure of sintered particles of polyethylene and said water-absorbent material.

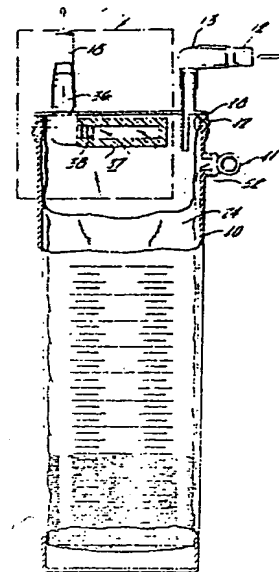

FOR THE PURPOSES OF INFORMATION ONLY

Codes used to identify States party to the PCT on the front pages of pamphlets publishing international applications under the PCT.

AT	Austria	GA	Gabon	MR	Mauritania
AU	Australia	GB	United Kingdom	MW	Malawi
BB	Barbados	HU	Hungary	NL	Netherlands
BE	Belgium	IT	Italy	NO	Norway
BG	Bulgaria	JP	Japan	RO	Romania
BR	Brazil	KP	Democratic People's Republic of Korea	SD	Sudan
CF	Central African Republic	KR	Republic of Korea	SE	Sweden
CG	Congo	LI	Liechtenstein	SN	Senegal
CH	Switzerland	LK	Sri Lanka	SU	Soviet Union
CM	Cameroon	LU	Luxembourg	TD	Chad
DE	Germany, Federal Republic of	MC	Monaco	TG	Togo
DK	Denmark	MG	Madagascar	US	United States of America
FI	Finland	ML	Mali		
FR	France				

- 1 -

FLUID-FLOW CONTROLLING DEVICE
AND APPARATUS EMPLOYING SAME

Field of the Invention

5 This invention relates to a device which is normally pervious to the flow of fluids through it, but which when it is contacted by a liquid becomes impervious to the flow of fluids. It relates also to the preparation of such a device and to apparatus utilizing the same, particularly in connection with the aspiration of body fluids from the
10 site of a body wound.

Such a device, which normally permits the ready flow of gas through it, but which when contacted by liquid becomes substantially impervious to the flow of gas or liquid, has many applications. However, it will be described hereinafter in detail with particular relation to
15 apparatus for aspirating body fluids from the site of a body wound, for example, during or after surgical operation. As is known, during and after a surgical operation, various liquids tend to accumulate at the site of the operation, especially blood, but also other body fluids such as:
20 lymphatic fluid, glandular fluid, fluids applied for medical purposes, etc. To aid in removing such fluids, it is common to provide an aspirating system comprising a flexible aspirating tube, the open free end of which is applied to the

- 2 -

region to be cleared of fluids and the other end of which is supplied with a vacuum, so that the liquids are drawn into the tube and removed from the surgical site by much the same basic principle as is employed in an ordinary vacuum cleaner.

5 Further, after the operation is over, it is common to maintain suction-type drains for continuously removing body fluids from the operation site.

10 In such a system, it is commonly desirable, and in some cases very important that the liquids so aspirated be collected locally in a suitable receptacle, so that the aspirated contents of the receptacle can be analyzed and/or disposed of in a sanitary manner. To this end, it is known to utilize a collecting container which is substantially air-tight except for an air inlet and an air outlet (see, for
15 example, U.S. Patent No. 3,704,709). The air inlet is connected to the end of an aspirating tube remote from the end at which aspiration of fluids from the patient occurs, and the outlet is connected to another tube which leads to the source of vacuum. Both inlet and outlet openings are
20 positioned well above the bottom of the container. Accordingly, liquids or other materials aspirated into the inlet in response to the action of the vacuum source fall to the bottom of the receptacle and are collected therein.

25 In such arrangement, it is of practical importance that the level of the liquid not be permitted to rise as high as the outlet opening. If the liquid level rises to the air outlet opening, liquid will begin to leave the collecting receptacle and flow into the vacuum line. This is generally undesirable for a number of reasons; first, if the vacuum
30 line is connected directly to the vacuum source, such suction of body liquids into it may contaminate and/or interfere with its proper operation over a period of time, and if as is often the case, a mechanical valve is included in the

- 3 -

suction line leading to the vacuum source to permit ready control of the connection of the vacuum source to the outlet of the collecting receptacle, spillage of the collected liquid into that valve may also interfere with its proper operation. In any event, such overflow from the container to the vacuum source will contaminate the vacuum source with whatever contaminants are present in the collected liquid. In addition, in many cases it is desired not to lose any liquid collected in the receptacle since it may be important to examine or analyze all of the liquid collected.

It is also desirable in many cases to filter the air sucked through the receptacle during normal operation, before it reaches the vacuum source, so as to prevent contamination of the vacuum source and the line leading to it with living contaminants such as bacteria, for example. Similarly, it is desirable also in certain situations to filter air that tends to be sucked into the collecting receptacle after the vacuum is terminated and as the vacuum tube between the source of the vacuum and the air outlet is opened or disengaged. Such filtering is designed to prevent contamination of the contents of the receptacle by contaminants such as bacteria, for example.

Reported Developments

In an effort to accomplish the foregoing, it is known to use a device which is secured to the underside of the lid closing the upper opening of the collecting receptacle and which senses the level of the collected liquid and terminates aspiration when a predetermined level somewhat lower than the outlet opening has been achieved. It is also known to include on the underside of the receptacle lid conventional porous or semi-porous filtering elements to prevent the passage of small amounts of the collected liquid

- 4 -

into the vacuum source and to remove certain types and sizes of bacteria or other living contaminants.

One type of device previously known and utilized for sensing the level of the liquid in the receptacle comprises in essence a float valve having a floatable element which floats at the surface of the collected liquid, at least when the receptacle is nearly filled. The float valve responds to raising of the liquid level beyond a predetermined desired position by closing off the inlet or outlet air openings, or both. An example of an aspirating system which includes the use of a float valve is disclosed in U.S. Patent No. 3,680,560.

Such arrangements, involving rather sensitive constructions which have critical moving elements, are relatively expensive to make and to maintain, particularly in view of the environment in which they operate. Inasmuch as it is often desirable to discard, or at least sterilize, everything in the receptacle, the possible inconvenience and cost of such arrangements will be apparent. This is particularly true in view of the fact that the presently most desired type of apparatus is one which can economically be completely discarded after each use, and in which the lid is therefore permanently secured to the receptacle and not designed for removal and reuse. In such cases in which the lid, receptacle, and the entire contents are discarded, the importance of an inexpensive arrangement for accomplishing the desired termination of the aspirating and receptacle filling operation is very apparent.

Another problem that has been encountered in an arrangement which involves the use of a float valve is that the valve tends to be activated prematurely as a result of contact with foam or froth that collects in the receptacle.

- 5 -

Blood, for example, is a natural frothing agent.

With respect to the use of heretofore known porous or semi-porous filtering elements which are affixed to the underside of the receptacle lid, and which function as both a valve and filter, such elements are generally made from hydrophobic polymeric materials such as, for example, polytetrafluoroethylene, polyester, poly(vinyl chloride), polypropylene, and polyethylene. Filter-valves made from such materials are disclosed in U.S. Patent No. 4,465,485. Experience has shown that, in operational procedures which utilize laser and/or electrical surgical devices, the smoke which emanates from the use of such devices tends to clog the filter-valve. Such clogging can substantially reduce the flow of air or even cut it off prematurely. In an attempt to overcome this problem, the aspirating system has been provided with a pre-filter to remove from the air, prior to its contact with the filter-valve, the smoke particles which cause the clogging. Polytetrafluoroethylene has also been used to form the pre-filter. Such a pre-filtering and filter-valve arrangement tends to be rather costly.

Another type of valve that has been described for use in apparatus for aspirating body fluids from the site of a body wound and in other types of apparatus, for example, a pipette, is disclosed in U.S. Patent No. 3,982,538. The valve disclosed in this patent comprises a container which is positioned in the path of liquid flow and which contains a powdered or granular, water soluble, polymeric material which permits the passage therethrough of air, but which, upon being contacted with an aqueous liquid, swells and blocks the passage therethrough of both liquid and air. The swelling of the water soluble polymeric material imposes limitations on the effective use of such a valve in various types

- 6 -

of applications. In addition, the valve does not function effectively when used in applications where the vacuum pressure is relatively high, as is desired in many types of applications. Also, the valve does not function effectively as a filter for relatively small size solids.

Accordingly, the present invention is directed to the provision of improved valve and/or filtering means which can be adapted for use in various types of applications, including particularly, aspirating systems of the type described above.

Summary of the Invention

In accordance with the present invention, there is provided a flow-control device comprising a water insoluble, highly water-absorbent material which is normally pervious, but which, upon contact with water, becomes substantially impervious to flow through it of liquid in the wetted regions thereof. One aspect of the present invention comprises a flow-control device comprising a body of porous material, the passages through which are normally sufficiently large to permit the flow of gas and aqueous liquid through them. The device comprises further a water insoluble, water-absorbent material which, upon contact with water, becomes substantially impervious to flow through it of gas and liquid in the wetted regions thereof. The device therefore can serve as an air and/or liquid valve which is automatically closed when the surfaces thereof are wet with aqueous liquid. Species of the water insoluble, highly water-absorbent material comprising the device of the present invention are known and forms thereof are available commercially. For convenience, said material is hereafter often referred to as "highly water-absorbent material".

- 6A -

In preferred form, the device can also be made to serve as a filter, for example, to filter out contaminating living organisms such as certain types of bacteria, thereby combining the functions of a liquid-operable valve for gas and liquid and a biological filter. The preferred form of such a valve filter/valve device comprises a porous rigid structure of sintered particles of the water insoluble, highly water-absorbent material and filler particles, for example, polyethylene particles. The preferred highly water-absorbable material is a hydrolyzed form of a graft copolymer prepared from starch and acrylonitrile, and is characterized by its ability to absorb at least about 100 parts of water per part of copolymer, and to maintain the absorbed water for a relatively long period of time, for example, at least about 4 hours.

It is theorized that the device functions in the following way. Upon contact with water, including, for example, aqueous body fluids, the particles of highly water-absorbent material substantially instantaneously absorb water and swell in a manner such that the spaces between the particles are filled, thereby rendering the normally pervious or porous structure impervious to the flow of both air and liquid. In the preferred form of the invention, the aforementioned expansion or swelling of the particles is effected in a manner such that neither the outer shape of the valve nor its gross volume changes to a significant extent.

- 7 -

In the application of the invention in which the device is utilized normally to permit the flow of aspirating gas through it, but to block the flow of aspirated liquids through it as soon as it is wet by an aqueous liquid, it may be positioned along the flow path of aspirated air prior to the point at which the presence of collected liquid in or from the receptacle will be harmful or undesirable. In one preferred embodiment, the device is positioned within the collecting receptacle below the level of the top of the outlet from the receptacle, and in the path of the air which flows from inlet to outlet opening of the receptacle. For example, it may be placed at the lower end of a short tube which leads upwardly to the air outlet. In the latter case, when the level of the liquid in the receptacle rises sufficiently to contact the device, the passage through it of both air and liquid is prevented, thus placing the valve in its closed condition. It may also be located at other positions within the receptacle or even in an outlet line leading from the outlet of the receptacle to the vacuum source, if desired.

In one preferred embodiment, the receptacle may be in the form of a closed, air-tight and air-impervious plastic bag, the top of which is closed by a lid. The lid is sealed to the end of the bag and contains spaced-apart inlet and outlet air flow openings. The bag is adapted to be placed within a rigid cylindrical canister having an open top onto which the lid can be pressed to form an air tight seal therewith. A vacuum line leads from the receptacle outlet to the source of vacuum, and the inlet opening is connected by a patient tube to the site from which aqueous fluid is to be aspirated.

- 8 -

When the system is operating, the liquid is aspirated from the patient site through the patient tube and into the interior of the plastic bag, where it falls to the bottom and collects. Preferably, a connection is also provided between the vacuum source and the interior of the canister outside of the bag so that the pressure on the inner and outer sides of the bag can be equalized to prevent its collapse during operation. When the liquid has risen sufficiently to cover and wet the outer surface of the automatic flow-control device of the invention, no further flow of liquid or air will occur. The device is preferably positioned so that this will occur before the liquid has reached the lid of the receptacle and the outlet opening. If desired, an indicator and/or alarm device can be provided to produce an alarm indication to the operator that the receptacle is filled, using for this purpose, for example, the change in suction pressure in the vacuum line which will occur when gas flow has been cut off as described above. The flow control device will also function to cut off outlet flow from the receptacle if the receptacle is accidentally tipped over.

Brief Description of Figures

Figure 1 is an idealized perspective view illustrating an application of the invention, in one of its preferred forms, to the aspirating of body liquids from a patient.

Figure 2 is a top plan view and Figure 3 is a side elevational view, with parts broken away, of a receptacle and canister arrangement in accordance with a preferred embodiment of the invention.

- 9 -

Figure 4 is an enlarged fragmentary view, in vertical section, of the top portion of the canister and receptacle assembly within the broken-line rectangle in Figure 3.

5 Figure 5 is a perspective view, with parts broken away, of one form of flow-controlling device in accordance with the invention, as used in the application of the invention shown in the foregoing drawings.

10 Figure 6 is a perspective view of a disc-shaped flow control device and/or filter according to the invention, as used in the embodiment of Figure 7.

15 Figure 7 is a fragmentary side elevational view, in section, showing a valve and/or filter assembly inside the receptacle and using the disc-shaped valve member of Figure 6 as the operative element.

And Figure 8 is a vertical sectional view showing a valve and/or filter assembly in series in the vacuum line and using the device shown in Figure 5.

20 Detailed Description of the Invention

Without thereby in any way limiting the scope of the invention, it will now be described with specific reference to preferred embodiments of the device, of systems employing it, and of methods of its manufacture and use.

25 Figure 1 shows the site 10 at which a surgical operation has been performed upon a patient, and a patient tube 12 which leads from that site to the inlet fitting 13 to aspirate liquids, including any gases or small particles

- 10 -

carried by the liquid, from the site of the operation to the nearby liquid-collecting system 14. A vacuum source 16, such as a hospital vacuum line, provides a suitable vacuum which normally acts through the vacuum line 18 and the liquid-collecting system 14 to produce suction at the free or aspirating end of the patient tube 12. An air check valve 20 may be included in series with the vacuum line. If desired, a suitable pinch valve can be provided near the aspirating end of the patient tube so that medical personnel may easily turn the aspirating action on and off at will.

Referring now to Figures 2-5 for further details of the collecting system 14, there is shown a receptacle 24 in the form of a flexible plastic bag, the top opening of which is sealed to a lower surface of a solid plastic lid 28. The seal between receptacle 24 and lid 28 may be provided by any suitable air-impervious adhesive. The hollow, tubular, inlet fitting 13 extends through and above and below the lid, as does the hollow, tubular, outlet fitting 36.

The flow control device 37 constructed in accordance with the invention is mounted on the end of outlet fitting 36 which lies within the receptacle 24, as by forcing it onto the nipple end 38 of the latter fitting, as shown more clearly in Figure 4.

The receptacle 24 is disposed within a canister 40, which may be of rigid plastic or metal and which provides mechanical support and protection for the bag assembly as well as support for a pressure-equalizing connector 41 used as described hereinafter to equalize the air pressure inside and immediately outside of the receptacle 24. It will be seen that a downwardly-extending rim portion 42 is provided on the lid 28 which can be readily snapped into air-tight relation with the top of the canister to complete the

- 11 -

assembly of receptacle and canister and to enable later
easy removal and discard of bag and lid. T-connector 41
provides communication at 52 between the vacuum line and
the interior of the canister, so that as the vacuum line
5 is evacuated, and the interior of the bag 24 therefore also
evacuated, a correspondingly reduced air pressure is pro-
duced within the canister outside of the bag so the bag
will not be subject to collapse during operation. The
portion of the vacuum line 18 extending from the air outlet
10 36 on lid 28 is connected to the T-connector 41 as shown
to complete the operative assembly.

During use then, after assembly of the system
has been completed as described above, and the vacuum source
is operating, liquids will be aspirated through the patient
15 tube 12 and the inlet fitting 13 into the interior of the
receptacle 24 where they will fall to the bottom of the bag
and accumulate as shown in Figure 3. When they have
accumulated to the level shown in Figure 4, the flow control
device of the invention will be covered with the accumulated
20 liquid, as a result of which it will become substantially
impervious to the flow of gas or liquid through it. This
therefore terminates the aspiration before the accumulated
liquid reaches the level at which undesired overflow from
the outlet fitting can occur. As mentioned above, suitable
25 indicator or alarm means can be provided to indicate when
this condition has been reached. The patient tube 12 can
then be disconnected from the lid 28, the vacuum line 18
is disconnected from the outlet fitting 36, the lid 28 and
the appended filled bag removed from the canister 40, and the
30 lid and bag assembly discarded. It will therefore be seen
that filling of the bag is automatically terminated as
desired, without requiring the use of any moving parts or
other complicated mechanism.

- 12 -

Figure 5 shows particular form for the filter and valve device itself, although it may take any of a large variety of different configurations in different applications. In this case, it is in the form of a cylinder which has a
5 dead-ended central bore 60 providing an end wall 62, so that the aspirated air must pass through a wall of the device to reach the interior of the outlet fitting 36, which terminates inside bore 60 as shown in Figure 3. Although this form of the flow control device of the present invention is shown for
10 use within the receptacle of an aspirating device, it can be used also in an aspirating device of the type in which the flow control device is located outside of the receptacle, for example, in an outlet line leading from the outlet of the receptacle to the vacuum source. Indeed, the form of the
15 device shown in Figure 5 is preferred for use as an "external" flow control device, for example, as shown in Figure 8.

In Figure 8, the flow-control assembly 140 is shown placed in series in the vacuum line 18 which extends from the outlet fitting 36 to the vacuum source 16 in Figure
20 1. The flow device itself may be the same valve cylinder 37, with a central dead-ended bore 60, as is shown in Figure 5. In this example, a circumferentially-ribbed, hollow, tubular stem 144 extends snugly into the bore 60, and communicates with a central opening in the outlet tube 148 which is
25 integral with stem 144. A circular flange 150, also integral with the stem and the tube, extends radially at the junction of stem and tube. An outer cylindrical casing 160 fits tightly about, and may be cemented to, a corresponding circular ledge 162 extending about the periphery of the flange, so
30 that the outer cylindrical casing 160 surrounds the valve cylinder 37 at a radial distance therefrom. The opposite end of the outer cylindrical casing is closed by a circular end wall 170 having a central opening 172 communicating with the interior of an inlet tube 178 which extends outwardly

- 13 -

therefrom. Inlet tube 178 also extends slightly into the outer cylindrical casing 160, is closed at its interior end, and has an opening 179 in its sidewall adjacent its interior end, so that the flow of air into the casing 5 160 will be diffused and distributed, rather than concentrated on the adjacent end of the valve cylinder. All parts of the assembly may be made of a transparent polyacrylic material, as an example.

Upon application of vacuum, air or other gases 10 from the upstream end of the vacuum line 18 will flow through inlet tube 178 to the interior of the plastic outer cylindrical casing 160, then through the wall of valve 37 to its central bore, and finally out of tube 148 to the downstream portion of vacuum line 18. If collected liquid 15 should flow from the receptacle 24 into the vacuum line 18, when the liquid reaches valve 37 the valve will become impervious to further flow of liquid or gas, as described previously, thus preventing flow of either type of fluid further into the vacuum line and system, as desired.

20 Figure 6 shows a particularly preferred form of a flow control device for use within the receptacle of an aspirating device, for example, as shown in the embodiment of Figure 7, in which the flow control assembly 100 is located inside the receptacle 24. This assembly uses 25 a valve in the form of the disc 102 of Figure 6, which is pressed into a circular recess 104 in the underside of the disc-supporting cup 106 until a marginal area of the upper side of the disc bears against the bottom of the internal ring-like band 108 in cup 106, to form a seal therewith; 30 the internal sidewalls 109 of the lower portion of the cup are tapered slightly inwardly along the upward direction, and the disc is inserted with the boss 110 positioned upwardly so that the inwardly-slanted portions 111 of the

- 14 -

edge of the disc mate with the inwardly-slanted internal sidewalls of the cup 106. The disc may be solvent-welded to the inner side walls of the cup into which it is thus placed. A plastic retaining ring 112 may then be formed
5 by heat-knurling the bottom end of the cup to bridge the space between the bottom of the cup and the marginal portions of the lower side of the disc, thereby to secure the disc positively in place.

The cup is also provided with a top opening
10 116 communicating with an integral upwardly-extending tube 120. The latter tube is slipped over the outside of a downwardly-depending hollow nipple 122 formed integrally on the underside of lid 28', and is cemented or otherwise secured thereto. The opening in the nipple is
15 aligned with an opening 124 extending through the lid 28' and communicating with the interior of the upwardly-extending tubular outlet fitting 36'. When fluid in the receptacle rises to the level at which the surfaces of disc 100 are wetted, further flow of air or gas is auto-
20 matically terminated as described previously.

The flow control device of the present invention comprises a material which is capable of absorbing a relatively large amount of water, for example, at least about 50 parts by weight of water per part by weight of
25 material. For use in collecting systems of the type described above, the highly water-absorbent material should resist being affected adversely as a result of contact with blood, body fluids, medications and other materials which may be encountered in such an aspirating application. In addi-
30 tion, the highly water-absorbent material should not be a source of contamination of the material which is collected in the receptacle of the collecting system. In situations where it is desired to analyze the collected materials, contamination thereof cannot be tolerated.

- 15 -

Presently, species of water insoluble, highly water-absorbent materials which can be used in the practice of the present invention comprise synthesized resins, including, for example, chemically treated naturally occurring polymeric materials and synthetic polymeric materials prepared by polymerization of monomers. An exemplary class of materials prepared from chemically treating naturally occurring polymeric materials comprise those which are synthesized from naturally occurring polymeric materials such as, for example, carboxymethylcelluloses, polysaccharides such as, for example, starch, and natural gums such as, for example, guar gum, and from vinyl compounds which are reactive there-with.

As mentioned above, species of the water insoluble, highly water-absorbent material comprising the flow-control device of the present invention are known. The following U.S. patents disclose examples of water-absorbent materials and processes for preparing the same: Nos. 3,425,971; 3,661,815; 3,997,484; 4,076,663 and 4,302,369. Speaking generally, the aforementioned patents are related to graft copolymers which are prepared from starch and acrylonitrile. Their disclosures are incorporated herein by reference with respect to the polymers described therein and the processes for preparing the polymers.

As set forth in aforementioned U.S. Patent No. 3,425,971, the water-absorbent polymer described therein is prepared by hydrolyzing a starch/polyacrylonitrile graft copolymer, the hydrolysis being effected by treating the polymer with an aqueous solution of an alkaline material or base, for example, potassium hydroxide to form a carboxylate. (The hydrolyzed form of the graft copolymer is characterized as containing both carboxyl and amide groups.) Addition of acid to the carboxylate forms the free acid which in turn can be precipitated from an alcohol solution. Aforementioned

- 16 -

U.S. Patent No. 3,661,815 discloses that the water-absorb-
ing properties of resins disclosed in the aforementioned
'971 patent are reduced upon contact with urine, and that
this problem can be overcome by conducting the aforemen-
5 tioned type of hydrolytic reaction or saponification with
an alkaline solution that includes alcohol. Aforementioned
U.S. Patent No. 3,997,484 discloses that the water-
absorbing properties of a hydrolyzed graft starch/poly-
acrylonitrile resin or starch/polymethacrylonitrile can be
10 increased by using gelatinizing starch to prepare the graft
copolymer. Insoluble resin can be obtained by evaporating
the aqueous alkaline solution that is used in the hydrolytic
or saponifying step. Aforementioned U.S. Patent No. 4,076,663
discloses the preparation of a water-absorbent resin pre-
15 pared by polymerizing the following monomers: (A) starch
or cellulose; (B) at least one monomer having a polymerizable
double bond which is water-soluble or becomes water-soluble
by hydrolysis; and (C) a cross-linking agent; and, if
necessary, subjecting the resulting product to hydrolysis.
20 Aforementioned U.S. Patent No. 4,302,369 discloses that
problems are encountered when highly water-absorbent resins
are subjected to water which contains free ions, for example,
sodium, and that such problems can be overcome by reacting
the hydrolyzed form of a starch or gelatinized starch/acrylo-
25 nitrile graft copolymer with aluminum to produce an aluminum
salt of the copolymer. Such resins are said to have an
enhanced degree of wicking and over-all improved water-
absorbing properties.

Exemplary water-absorbing properties of resins
30 which are the subjects of said patents have the capability
of absorbing about 50 to about 1000 parts or more of water
per part of resin. Such resins can be produced in water-
insoluble granular form and have the ability to absorb such
large amounts of water while retaining their granular form.
35 Various of the aforementioned patents disclose that

- 17 -

water-absorbing resins of the type disclosed therein can be used in many types of applications including, for example, as water or body-fluid absorbents in diapers, sanitary napkins, bed or surgical pads, and disposable dust cloths, and to increase the water-holding capacity of soils, and as coatings for seeds, clay, starch, fibers, paper and the like. In addition, U.S. Patent No. 4,421,129 discloses the use of such resins in preparing shaped articles which can be used to rapidly dry hair. Examples of such articles include combs, hair brushes, and hair curlers which are made by molding a powdery form of the highly water-absorbent polymer in a mold under pressure and at ambient temperature. Such articles take advantage of those properties of the water-absorbent resin by which large quantities of water are quickly absorbed in a short time, for example, within minutes, without causing a change in the gross shape of the article. The rate at which absorbed water evaporates from the resin varies depending on the resin, the evaporation rate for some resins being substantially the same as that of water of similar surface area. As water evaporates from the resin, it is capable of being reused to absorb water.

It should be understood that water insoluble, highly water-absorbent materials other than the graft starch polymers mentioned above can be used in the practice of the present invention. Examples of such resins include cross-linked poly(alkylene oxide) resins, cross-linked polyacrylate resins, and cross-linked carboxy methylcellulose resins. Species of such resins are known and include materials which are available commercially. The following U.S. patents disclose examples of additional species of water-absorbent resins: Nos. 3,264,202; 3,898,143 and 3,956,224.

Examples of commercially available water-absorbent resins include the following trademark products sold by Grain

- 18 -

Processing Corporation: Water-Lock A-100 characterized as being insoluble in most organic solvents, resistant to body fluid enzymes and capable of absorbing dilute aqueous acid and alkali solutions, and having the ability to absorb at least 110 ml of water/g of resin; Water-Lock J-500 characterized as being capable of absorbing at least about 500 ml of water/g of resin; and Water-Lock J-550 characterized as being capable of absorbing at least 375 ml of water/g of resin. Such resins are described by their manufacturer as being super absorbent products which are prepared by hydrolyzing starch/acrylonitrile graft copolymers to form polymeric products having side chains which contain carboxamide and carboxylate groups. The aforementioned resins are available commercially as free flowing powders. Other sources of the resins include Arakawa Chemical (U.S.A.) Inc. which sells their resins under the trademark "ARASORB", Sanyo Chemical, Unilever, Hercules, and Dow Chemical.

The flow control device of the present invention can be made entirely from the water insoluble, highly water-absorbent material or a mixture of such materials, or it can be made from such material(s) and one or more other materials, including major amounts of such other materials. Examples of classes of such other materials include carriers, fillers, and additives which improve the physical and/or chemical properties of the composition comprising the device. In this regard, the composition can comprise, for example, polyethylene, acrylic resin, and nylon (to name but a few), a filler material(s) such as, for example, calcium carbonate, lubricant, anti-oxidant, fibers, including both synthetic and natural fibers, and materials which modify one or more of the aesthetic, physical and chemical properties of the composition, for example, molybdenum disulfide. Synthetic resins which are capable of being sintered can be used to good advantage in the practice of the present invention. Polyolefins, particularly polyethylenes and polypropylenes, are preferred examples of such materials.

- 19 -

With regard to a flow control device for use in an aspirating system of the type described above, particularly good results have been achieved by fabricating such device from a mixture of the highly water absorbent resin and of water insoluble polymeric carrier or filler particles.

An attractive feature of the present invention is that relatively small amounts of the highly water-absorbent resin can be used in fabricating the flow-control device. Thus, a minor amount of the resin can be combined with a major amount of the carrier or filler material(s), including material(s) which is less costly than the water-absorbent resin. In addition to cost advantages, the strength of the device can be improved by the use of a carrier material, preferred materials being polyethylenes, and polypropylenes having a molecular weight of at least about 900,000 to several million. (Lower molecular weight polyolefins whose molecular weight can be increased by chemical modification such as, for example, irradiation and peroxide treatment of the polymer, can be used also.) It is preferred also that the melt index of such polymeric materials be less than 1. Based on cost, ease of manufacture, and performance, polyethylenes having a molecular weight of at least about 2.5 million and a melt index below 1 are particularly desirable material for use in the present invention. Recommended commercial products are those sold under the trademark HOSTALEN GUR and HIMONT, for example HOSTALEN GUR 412, 413, and 415, and HIMONT HB 312.

Accordingly, the amount of water-absorbent resin comprising the fluid-control device can vary over a wide range, the minimum amount being dictated by that needed to block the passage of the aqueous fluid through the device as it is contacted therewith, and the maximum amount being about 100 wt.% of the resin. For example, a device within the present invention can comprise about 0.5 to about 99

- 20 -

wt.% of the water-absorbent resin and about 1 to about 99.5 wt.% of filler. Preferred amounts of constituents comprise about 5 to about 15 wt.% resin and about 85 to about 95 wt.% filler.

5 The device of the present invention can be made in various ways, including, for example, by the method disclosed in aforementioned U.S. Patent No. 4,421,129 for fabricating the hair drying devices described therein. This method involves basically forming the article by injection
10 or compression molding techniques utilizing elevated pressures and ambient temperature. For example, powdered resin is placed into a hardened steel mold and formed into an article of the desired shape at pressures of about 200 to about 40,000 psi at ambient temperature and within one
15 minute. Elevated temperatures can be used also in the molding operation.

- 21 -

Examples

Examples which follow are illustrative of the fabrication of fluid-control devices within the scope of the present invention.

5 Example 1

A fluid-control device as shown in Figure 5 was made in the following manner. The device had an overall length of 2.1 inches, a bore length of 1.9 inches, an overall diameter of 0.69 inch and a bore diameter of 0.295 inch.

10 The device was fabricated from a composition comprising: (A) 90 wt.% of powdered polyethylene having a molecular weight of about 3.5 million, a melt index below 1, and a spherical particle size diameter of about 50 microns; and (B) 10 wt.% of highly water-absorbent resin particles
15 comprising a hydrolyzed form of a starch/acrylonitrile copolymer sold by Grain Processing Corporation under the trademark Water-Lock A-200.

The resin and polyethylene particles were ball-milled to produce a mixture in which particles of the water-absorbent resin were adhered to the larger size particles
20 of polyethylene. The resin mixture was placed into an approximately shaped mold and then made into the fluid-control device by compression molding at a temperature of about 375°F and a pressure of about 1000 psi, and for a time of
25 about 10-15 minutes.

The device had a pore size of about 5 microns. Evaluating work showed that the device was capable of: (A) filtering 99.8% of bacteria as small as Pseudomonas diminutae and 100% of larger bacteria; and (B) holding fluids of the
30 type collected in the receptacle of the collecting system described above for in excess of 8 hours.

- 22 -

In use in an aspirating system of the type described above, the fluid-control device of Example 1 immediately upon being wetted with the liquid contents of the receptacle prevented passage thereof beyond the device.

5 It has been observed that foam generated from materials such as blood, soap and egg whites do not adversely affect the function of the device, nor does it cause a slow down or premature termination of air flowing therethrough. It has been observed also that, in use, the flow-control device

10 of Example 1 permitted the passage therethrough of laser plume with minimal air flow restrictions. The device was used in an application which included an initial air flow in the range of about 3.6 to about 5 cubic ft/min and with air flow at the patient site being no less than about 2.6

15 cubic ft/min, a satisfactory value.

Example 2

A flow-control device as shown in Figure 5 and described in Example 1 is made, as described in Example 1, but with somewhat different dimensions, the device being

20 contemplated for use as an "external" filter/valve in an aspirating device. The device has an overall length of 1.7 inches, a bore length of 1.5 inches, an overall diameter of 1 inch and a bore diameter of 0.6 inch. The flow-control device has a uniform porosity of about 9.75 micron pore

25 radius and a pore volume of about 50%. It is capable of operating at a source vacuum of about 3 SCFM (24" Hg) with an air flow of no less than about 2.5 SCFM - even when exposed to laser plume for 2 hours. Under use conditions, the flow-control device is capable also of not permitting

30 any fluid to pass through it for at least 8 hours. Filtering characteristics include the ability of filtering more than 99% of Pseudomonas diminutae and 100% of Micrococcus luteus and B. subtilis.

Example 3

A flow control device in the form of a disc, as shown in Figure 6, is made from a composition like that described in Example 1 and in the manner described in

5 Example 1. The diameters of the lower and upper surfaces of the disc are respectively 2.43 and 2.40 inches. The thickness of the disc is 0.2 inch. The inwardly slanted portions of the edge of the disc are inclined at an angle of 5°, with the slanted portions beginning at a distance

10 of 0.05 inch from the lower surface of the disc. The porosity and pore volume of the device are like those of the device of Example 2 and its operating characteristics are also like those of the device of Example 2.

The embodiments described above are shown for

15 use in apparatus for aspirating body fluids from the site of a body wound. The apparatus which is illustrated functions by virtue of the use of reduced pressure or vacuum which draws liquid away from the body and into the apparatus. Devices within the scope of the present invention can be

20 used also in other types of applications involving the use of a vacuum pump to protect the pump from undesired contact with fluids. It should be understood that devices within the scope of the present invention can be used also in other types of applications, including, for example, applications

25 in which gas flow through the device is under positive pressure.

- 24 -

I Claim:

1. A non-mechanical valve for automatically controlling the flow of liquid through it comprising:

a porous structure, the internal passages through which are normally sufficiently large in cross-sectional area to permit the flow of gas and liquid through them;

means for supplying gas at a first pressure to one region of said structure while maintaining a second lower gas pressure at another region of said structure, normally to induce a flow of said gas through said structure;

means for mounting said structure in a position in which the portion thereof between said one and said another region thereof is subject to wetting by an aqueous liquid;

wherein said structure comprises water insoluble material which is swellable in response to wetting thereof by said aqueous liquid so as to close said passages substantially completely when said structure is wetted, thereby to prevent subsequent flow of gas and liquid through said structure.

2. The valve of Claim 1, wherein said cross-sectional areas of said passages, prior to said wetting, are sufficiently small for said structure to act as a bacterial filter.

3. The valve of Claim 2, wherein the size of said passages is such that bacteria having the size of Pseudomonas diminutae bacteria and bacteria of larger size are prevented from passing through said porous structure.

4. The valve of Claim 1, wherein said material comprises a hydrolyzed starch/acrylonitrile graft copolymer.

- 25 -

5. The valve of Claim 1 or 4, wherein said structure comprises a mixture of said material and also filler.

6. The valve of Claim 5, wherein said filler consists essentially of high molecular weight polyethylene.

7. The valve of Claim 4, wherein said copolymer is capable of absorbing at least about 110 ml of water/g of copolymer.

8. In an aspirating system for removing liquids from the vicinity of a living body, comprising a vacuum source, an aspirator tube, one end of which is adapted to be placed in the immediate vicinity of said body to aspirate liquids therefrom, a liquid-collecting receptacle having an inlet and an air outlet, first means connecting the other end of said aspirator tube to said air inlet, a vacuum line operatively connecting said vacuum source to said air outlet, said inlet and said outlet both being spaced from the bottom of said receptacle whereby said receptacle may be filled to a substantial depth with said liquid before the level of said liquid reaches said inlet or said outlet: means for preventing said collected liquid from passing out of said air outlet of said receptacle and beyond a predetermined point in said vacuum line, comprising a normally gas- and liquid-pervious flow-control member positioned in the path of the collected liquid between a point in the interior of said receptacle and said predetermined point in said vacuum line, said flow-control member comprising a water insoluble, highly water-absorbent material normally pervious to flow of said gas and said liquid but in response to wetting by said liquid becoming impervious to flow of said gas and liquid, thereby to block flow of said liquid through said flow control member after said liquid has wet said member.

- 26 -

9. The system of Claim 8, wherein said flow-control member is positioned in said container adjacent said air outlet, in the path of air flow into said outlet.

10. The system of Claim 8, wherein said flow-control member is positioned outside said container in said vacuum line.

11. A valve comprising about 0.5 to about 99 wt.% of a water insoluble, water absorbent resin capable of absorbing at least about 50 g of water/g of resin and about 1 to about 99.5 wt.% of filler.

12. A valve according to Claim 11 wherein said filler comprises water insoluble synthetic resin which is capable of being sintered.

13. A valve according to Claim 12 wherein said synthetic resin consists essentially of a polyolefin.

14. A valve according to Claim 13 wherein said polyolefin is a polyethylene or polypropylene having a molecular weight of at least about 900,000.

15. A valve according to Claim 14 wherein said polyolefin is polyethylene having a molecular weight of at least about 2.5 million and a melt index below 1.

16. A valve according to Claim 11, 12, 13, 14 or 15 comprising about 5 to about 15 wt.% of said resin and about 85 to about 95 wt.% of said filler.

17. A valve according to Claim 16 wherein said water absorbent resin is a hydrolyzed starch/acrylonitrile graft copolymer.

- 27 -

18. A composition comprising a water insoluble, water absorbent resin capable of absorbing at least 50 g of water/g of resin and a water insoluble synthetic resin which is capable of being sintered.

19. The valve of Claim 1, wherein said first pressure is ambient pressure and said second pressure is below ambient pressure.

FIG. 1.

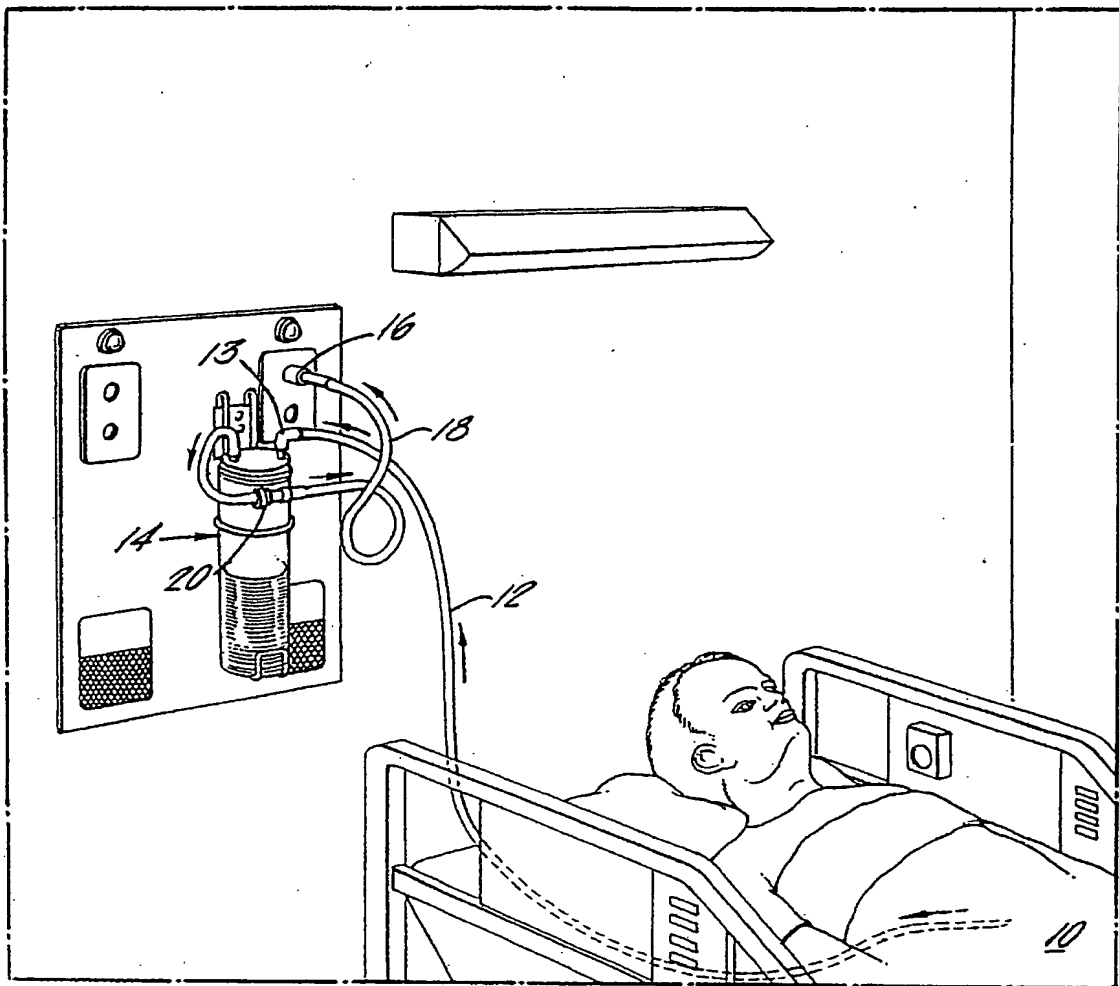

FIG. 2.

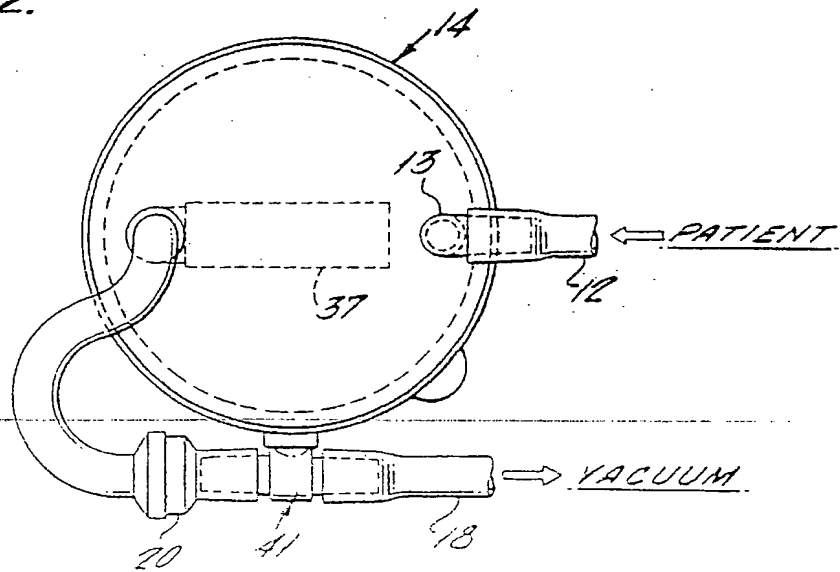

Fig. 3.

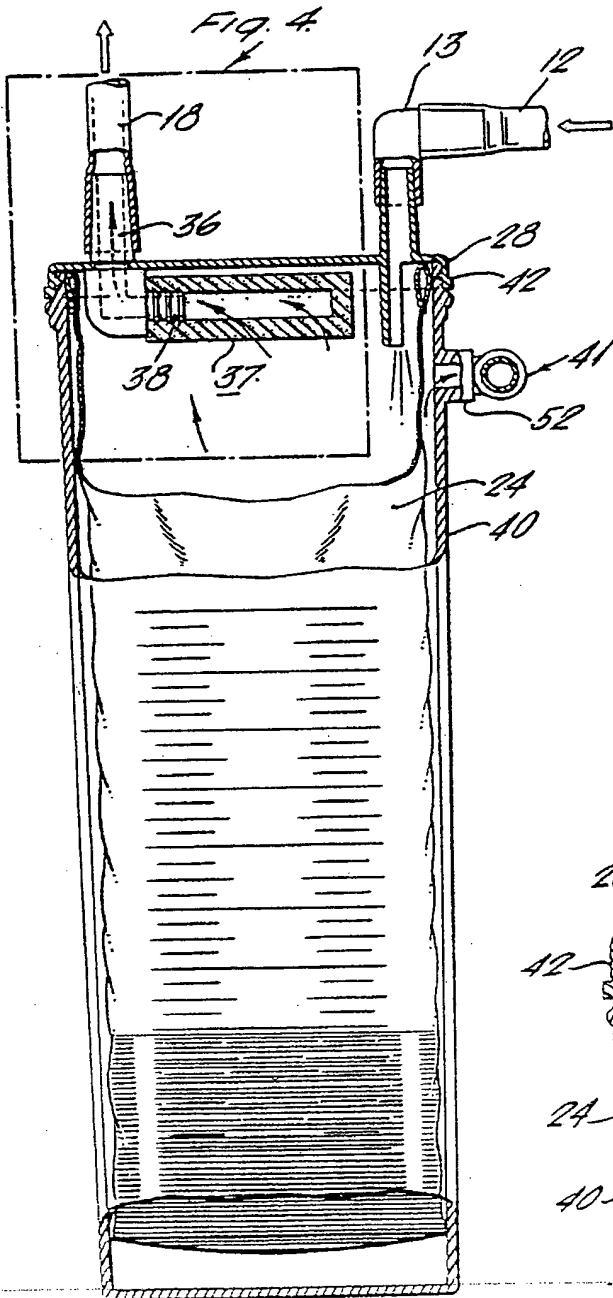

Fig. 5.

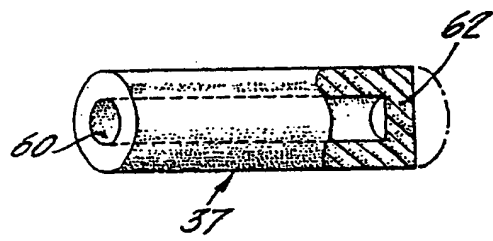

Fig. 4.

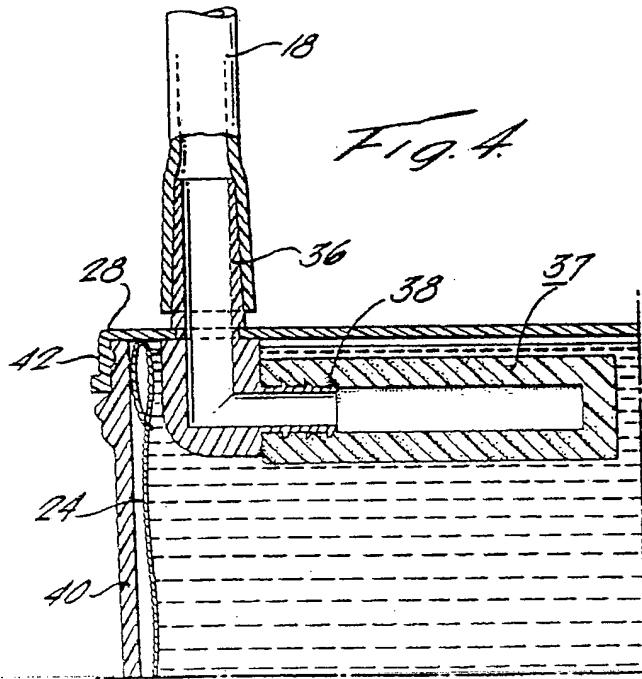

Fig. 6.

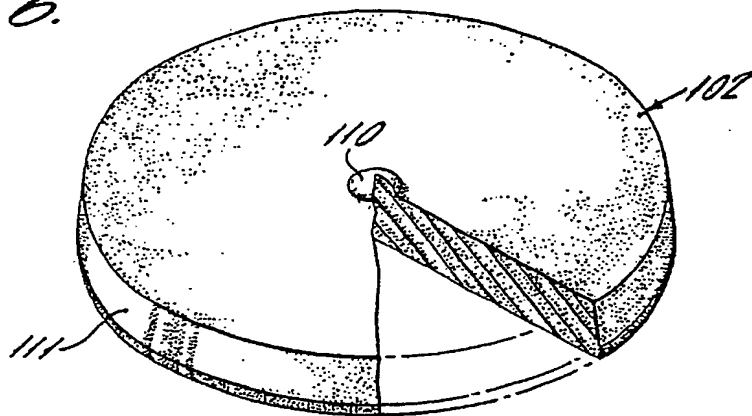

Fig. 7.

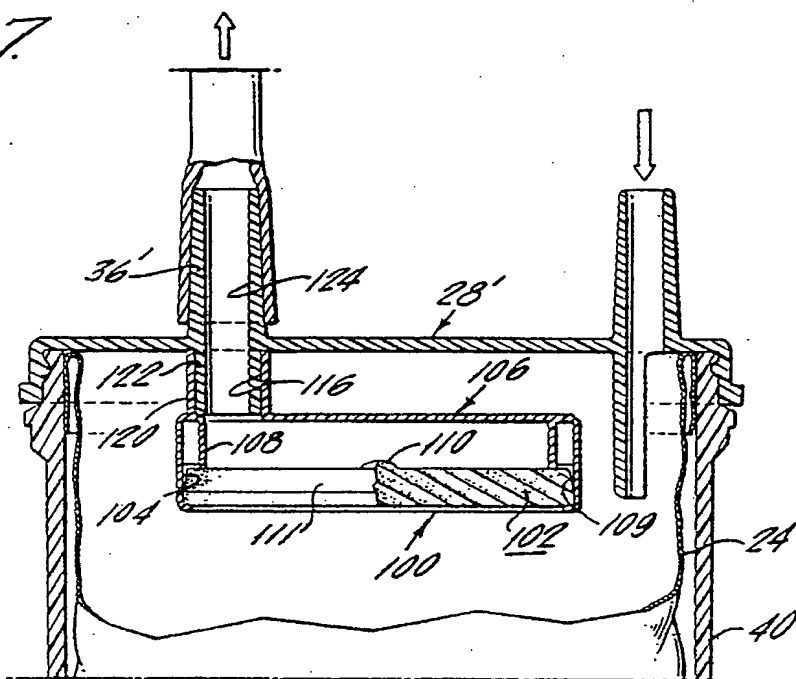
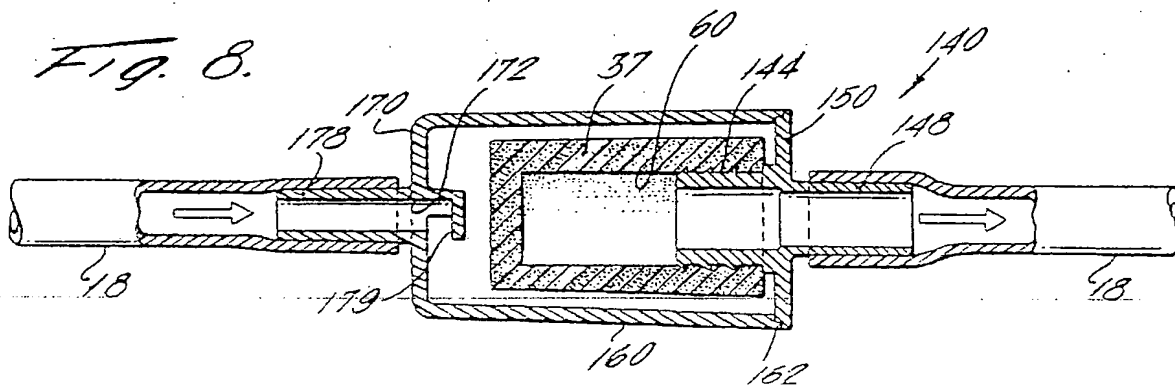
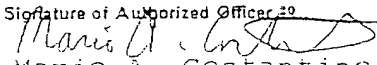

Fig. 8.



INTERNATIONAL SEARCH REPORT

International Application No PCT/US86/01502

I. CLASSIFICATION OF SUBJECT MATTER (if several classification symbols apply, indicate all) ³		
According to International Patent Classification (IPC) or to both National Classification and IPC		
IPC (4): A61M 1/00; F16T 1/00		
U.S. Cl. 604/320; 137/199		
II. FIELDS SEARCHED		
Minimum Documentation Searched ⁴		
Classification System	Classification Symbols	
U.S.	604/65, 126, 317-321; 128/760, 766, 771	
U.S.	55/523; 137/197, 199	
Documentation Searched other than Minimum Documentation to the Extent that such Documents are Included in the Fields Searched ⁵		
III. DOCUMENTS CONSIDERED TO BE RELEVANT ¹⁴		
Category ⁶	Citation of Document, ¹⁶ with indication, where appropriate, of the relevant passages ¹⁷	Relevant to Claim No. ¹⁸
X Y	US, A, 3,932,538 (SHARPE) 28 SEPTEMBER 1976, see column 1, lines 1-57, 66-68; column 2, lines 1-16, 53-59, 66-68; column 3, lines 9-15; column 4, lines 5-10, 25-29.	1-3, 5, 8-11, 19 4-7, 12-17
X Y	US, A, 3,898,143 (ASSARSSON et al) 05 AUGUST 1975, see column 1, lines 20-28, 63-68; column 4, lines 23-44.	18 6, 12-17
Y	US, A, 3,661,815 (SMITH) 09 MAY 1972, see column 1, lines 13-58; column 2, lines 4-24; and Table X.	4-7, 17
A	US, A, 4,076,663 (MASUDA et al) 28 FEBRUARY 1978, see entire document.	4, 7, 11, 17, 18
A	US, A, 4,228,798 (DEATON) 21 OCTOBER 1980, see column 2, lines 6-34; column 3, lines 45-60; column 4, lines 55-65; column 6, lines 48-63; column 7, lines 10-28; column 8, lines 8-56; column 14, lines 23-68; column 15, lines 1-54. (Cont. on extra sheet)	
<p>¹⁵ Special categories of cited documents:</p> <p>"A" document defining the general state of the art which is not considered to be of particular relevance</p> <p>"E" earlier document but published on or after the international filing date</p> <p>"L" document which may throw doubts on priority claim(s) or which is cited to establish the publication date of another citation or other special reason (as specified)</p> <p>"O" document referring to an oral disclosure, use, exhibition or other means</p> <p>"P" document published prior to the international filing date but later than the priority date claimed</p> <p>"T" later document published after the international filing date or priority date and not in conflict with the application but cited to understand the principle or theory underlying the invention</p> <p>"X" document of particular relevance; the claimed invention cannot be considered novel or cannot be considered to involve an inventive step</p> <p>"Y" document of particular relevance; the claimed invention cannot be considered to involve an inventive step when the document is combined with one or more other such documents, such combination being obvious to a person skilled in the art.</p> <p>"&" document member of the same patent family</p>		
IV. CERTIFICATION		
Date of the Actual Completion of the International Search ¹⁹		Date of Mailing of this International Search Report ²⁰
08 SEPTEMBER 1986		01 OCT 1986
International Searching Authority ¹		Signature of Authorized Officer ²⁰
ISA/US		 Mario A. Costantino

III. DOCUMENTS CONSIDERED TO BE RELEVANT (CONTINUED FROM THE SECOND SHEET)		
Category *	Citation of Document, ¹⁶ with indication, where appropriate, of the relevant passages ¹⁷	Relevant to Claim No ¹⁸
A	US, A, 4,328,828 (CIANCI) 11 MAY 1982, see column 3, lines 51-58.	
A	US, A, 4,465,485 (KASHMER et al) 14 AUGUST 1984, see column 3, lines 46-63.	

THIS PAGE BLANK (USPTO)